

# Butt-Weld Fittings

# LR 90° Elbows

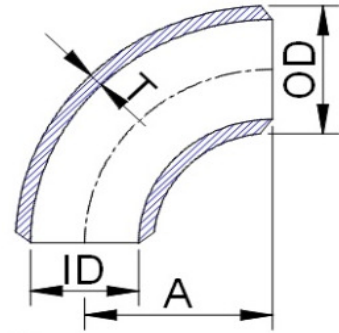

Pipe Size	Outside Diameter	Inside Diameter	Wall Thickness	Center to End	Pipe Schedule Number	Approx. Weight in Pounds
	O.D.	I.D.	T	A		
1/2	0.84	0.622	0.109	1.5	40/STD	0.16
3/4	1.05	0.824	0.113	1.5	40/STD	0.17
1	1.32	1.054	0.133	1.5	40/STD	0.4
1 1/4	1.66	1.38	0.14	1.88	40/STD	0.55
1 1/2	1.9	1.61	0.145	2.25	40/STD	0.8
2	2.38	2.072	0.154	3	40/STD	1.6
2 1/2	2.88	2.474	0.203	3.75	40/STD	3.2
3	3.5	3.068	0.216	4.5	40/STD	4.8
3 1/2	4	3.548	0.226	5.25	40/STD	6.6
4	4.5	4.026	0.237	6	40/STD	8.9
5	5.56	5.044	0.258	7.5	40/STD	15.1
6	6.62	6.06	0.28	9	40/STD	24
8	8.62	7.976	0.322	12	40/STD	47.8
10	10.75	10.02	0.365	15	40/STD	83.4
12	12.75	12	0.375	18	STD	123
14	14	13.25	0.375	21	30/STD	155
16	16	15.25	0.375	24	30/STD	206
18	18	17.25	0.375	27	STD	262
20	20	19.25	0.375	30	20/STD	324
24	24	23.25	0.375	36	20/STD	466
30	30	29.25	0.375	45	STD	720
36	36	35.25	0.375	54	STD	1039
42	42	41.25	0.375	63	STD	1420
48	48	47.25	0.375	72	STD	2000

Pipe Size	Outside Diameter	Inside Diameter	Wall Thickness	Center to End	Pipe Schedule Number	Approx. Weight in Pounds
	O.D.	I.D.	T	A		
1/2	0.84	0.546	0.147	1.5	80/XH	0.26
3/4	1.05	0.742	0.154	1.5	80/XH	0.29
1	1.32	0.962	0.179	1.5	80/XH	0.48
1 1/4	1.66	1.278	0.191	1.88	80/XH	0.79
1 1/2	1.9	1.5	0.2	2.25	80/XH	1.2
2	2.38	1.944	0.218	3	80/XH	2.1
2 1/2	2.88	2.328	0.276	3.75	80/XH	3.8
3	3.5	2.9	0.3	4.5	80/XH	6.3
3 1/2	4	3.364	0.318	5.25	80/XH	8.6
4	4.5	3.826	0.337	6	80/XH	12.5
5	5.56	4.81	0.375	7.5	80/XH	21.2
6	6.62	5.756	0.432	9	80/XH	34.4
8	8.62	7.62	0.5	12	80/XH	71.3
10	10.75	9.75	0.5	15	60/XH	111
12	12.75	11.75	0.5	18	XH	158
14	14	13	0.5	21	XH	201
16	16	15	0.5	24	40/XH	270
18	18	17	0.5	27	XH	348
20	20	19	0.5	30	30/XH	422
24	24	23	0.5	36	XH	604
30	30	29	0.5	45	20/XH	997
36	36	35	0.5	54	20/XH	1380
42	42	41	0.5	63	XH	1880
48	48	47	0.5	72	XH	2502

Pipe Size	Outside Diameter	Inside Diameter	Wall Thickness	Center to End	Pipe Schedule Number	Approx. Weight in Pounds
	O.D.	I.D.	T	A		
12	12.75	11.938	0.406	18	40	123
14	14	13.124	0.438	21	40	155
16	16	15	0.5	24	40	206
18	18	16.876	0.562	27	40	262
20	20	18.812	0.594	30	40	324
24	24	22.624	0.688	36	40	466

Pipe Size	Outside Diameter	Inside Diameter	Wall Thickness	Center to End	Pipe Schedule Number	Approx. Weight in Pounds
	O.D.	I.D.	T	A		
10	10.75	9.562	0.594	15	80	111
12	12.75	11.374	0.688	18	80	158
14	14	12.5	0.75	21	80	201
16	16	14.312	0.844	24	80	270
18	18	16.124	0.938	27	80	348
20	20	17.938	1.031	30	80	422
24	24	21.562	1.219	36	80	604

**LOS ANGELES** 800-456-8526    **HOUSTON** 800-727-8526  
**CONCORD** 800-759-7303    **BATON ROUGE** 866-941-8526  
**BAKERSFIELD** 800-975-0059    **CHICAGO** 800-463-8526  
**DENVER** 800-666-8526    **PHILA/NJ** 800-898-8526

